

MASSA[®]

1975

PRODUCER OF SPECIAL ALLOYS SINCE

**DENTAL ALLOYS AND
OVERCASTABLE
ABUTMENTS**





03

The Company

05

Quality & certifications

07

Properties of common Chrome-Cobalt alloys

09

Why choose Mesa Chrome-Cobalt alloys?

11

Dental alloys for ceramics

17

Dental alloys for plate prostheses

20

Dental alloys for bridges and crowns

22

Dental alloys for welding

25

Discs and bars for Cad/Cam processing

26

Chrome-cobalt Discs for Cad-Cam processing

27

Chrome-Cobalt Bars for Cad-Cam processing

30

Titanium discs for Cad-Cam processing

33

Ergal discs for Cad-Cam processing

34

Chrome-Cobalt and Titanium Qbar

37

Overcastable abutments

38

Mesa overcastable' features

39

Why choose Mesa Overcastable Abutments?

40

Tips for casting Mesa Overcastable Abutments

41

Compatible Overcastable Cr-Co components



THE COMPANY



Mesa Italia is a leading Italian company in the production of alloys for the dental sector since 1975. The strength of Mesa is the long family tradition which allowed the founder Giacomo Sala to share the same creative ambition with his three sons Lorenzo, Valerio and Rita, promoting a product whose quality is recognized both nationally and internationally.

Mesa stands out for its flexibility, which enables it to quickly and efficiently meet the ceaseless changing needs of the markets.

The patients' health and well-being has always been considered by the company as its major priority. Relying on its know-how and on its research and design competence, the company produces only alloys that comply with top quality, safety and reliability features.



Health Canada
Licences N°: 101164
99138
99139
105521

FDA Registered Facility
Owner/Operator
Number 10044677

РЕГИСТРАЦИОННОЕ
УДОСТОВЕРЕНИЕ
НА МЕДИЦИНСКОЕ
ИЗДЕЛИЕ № РЗН
2021/14248

РЕГИСТРАЦИОННОЕ
УДОСТОВЕРЕНИЕ
НА МЕДИЦИНСКОЕ
ИЗДЕЛИЕ № РЗН
2014/2226

QUALITY & CERTIFICATIONS



The rigorous selection in the purchase of raw materials allows us to guarantee, for each product, **the total absence of Beryllium and Cadmium and the absence of Nickel in all the Cobalt-based alloys.**

MESA Italia Srl complies with the most recent Quality Standards and respects the strictest international criteria in the production of class IIa and IIb medical devices, keeping its Quality Management System constantly updated in compliance with **UNI EN ISO 13485:2016**, **UNI EN ISO 9001:2015** and **MDSAP** (Medical Device Single Audit Program).

Therefore, the organization has obtained marketing authorization for its devices from the bodies of the 5 countries adhering to the MDSAP:

Food & Drug Administration FDA, United States of America - Anvisa, Brazil - Ministry of Health Labor and Welfare MHLW, Japan - Health Care Ministry, Canada - Therapeutic Good Administration TGA, Australia.

The company also has EC markings in compliance with Directive **93/42/EEC (MDD)** and Regulation **(EU) 2017/745 (MDR)** for the sale of all medical devices in the member countries of European Union, issued by ICIM SpA notified body.

In particular, for all dental alloys, on February 2023 the company received the EC certification according to Regulation **(EU) 2017/745 (MDR)**.

Mesa Italia Srl has also obtained sales licenses in many other countries including:

Eastern Europe (Russia, Ukraine, Belarus...)

Asia (China, South Korea, Kazakhstan, Malaysia, Turkmenistan...)

Maghreb (Egypt, Tunisia and Algeria)

South America (Colombia, Honduras, Argentina and Perù)



PROPERTIES OF COMMON CHROME-COBALT ALLOYS



Chrome-Cobalt alloys, erroneously called “vile” and often labeled as “non-noble”, have common **properties and peculiarities** that make them precious for dental laboratories.

- **High stiffness**

The high modulus of elasticity of the Co-Cr alloys offers a proper rigidity for intraoral use without the need for bulky sections, reducing the weight and space of the metal structure.

- **Strength**

Great specific strength due to the crystallographic nature of cobalt and the reinforcing effect provided by chromium and other elements present in solid solution.

- **Corrosion resistance**

This assumption is necessary for good tolerability of the prosthetic restoration.

- **Excellent biocompatibility**

Absence of dangerous metals such as Beryllium, Cadmium, Nickel.

- **Wear and abrasion resistance (wear resistance)**

- **Density lower than gold alloys**

- **Weight reduction of the prosthesis**

- **Absence of magnetic properties**

- **Affordability**



WHY CHOOSE MESA[®] CHROME-COBALT ALLOYS?



Mesa Italia, thanks to a daily discussion with a team of highly qualified dental technicians, has managed to overcome common defects like thicker and darker oxide layers, greater hardness, higher melting range, improving the quality and workability of the Chrome-Cobalt alloys compared to common alloys.

- **Mild, non-aggressive oxidation** of Mesa Magnum Lucens alloy: the oxidation is linked to the metal and does not create ceramic detachments.
- **Excellent flowability** of Mesa Magnum Lucens alloy: it guarantees the technician to reproduce even the finest details making this alloy excellent in lost wax castings.
- **Excellent polishability** of Mesa Magnum Splendidum and Magnum Solare alloys: they are easily milled thanks to a perfect balance between Vickers Hardness and modulus of elasticity which avoids damage to the ceramics and at the same time allows excellent workability.
- **CNC milling** of Mesa Magnum Solare and Magnum Splendidum alloys: they are easily milled due to their low hardness.
- **Melting temperature and solidus/liquidus temperature (1253-1304°C)** of Mesa Magnum Lucens alloy lower than the standard Chrome-Cobalt alloys: 80 °C of difference which can limit the wear of the induction machine or of the die casting.

The strengths of our main Chromium-Cobalt dental alloys have been summarized in the table below, in terms of oxidation, smoothness, polishing, ceramization and CNC milling so as to more easily orient the choice of the most suitable product for different needs.

	Oxidation	Smoothness	Polishing	Ceramization	CNC milling
M. Solare	XX	X	XXX	XX	XXX
M. Splendidum	XXX	XXX	XXX	XXX	XXX
M. Lucens	XXX	XXX	XXX	XXX	XX

Legend: X = sufficient XX = good XXX = excellent



DENTAL ALLOYS FOR CERAMICS

CHARACTERISTICS OF MESA DENTAL ALLOYS FOR CERAMICS:

- All Mesa alloys for ceramics are manufactured in accordance with ISO 9693:2019 and ISO 22674:2016.
- **Strictly free of toxic elements:** Beryllium, Cadmium, Lead, Indium and Gallium.
- **Universal use:** crowns and bridges, double crowns, implant superstructures, luting technique, secondary parts in combination prosthetics.
- **Perfectly ceramizable:** low coefficient of thermal expansion (CTE).
- **High degree of purity.**
- **High resistance to corrosion and heat.**

Chrome-Cobalt **CE0425** ACCORDING TO: ISO 9693, ISO 22674

MAGNUM SPLENDIDUM TYPE 3

Composition		Physical and mechanical features	
Cobalt (Co)	60%	Solidus-liquidus temperature	1308 ÷ 1384 °C
Chrome (Cr)	28%	Thermal expansion coefficient	(25 ÷ 500 °C) 14,2 x 10 ⁻⁶ K ⁻¹
Silicon (Si)	1,5%		(25 ÷ 600 °C) 14,4 x 10 ⁻⁶ K ⁻¹
Tungsten (W)	9%	Melting point	1440 °C
Others	Mn, Fe	Density	8,5 g/cmc
		Vickers hardness	273 HV10
		Percentage elongation at fracture	16 %
		Yield load strength (Rp0.2)	360 MPa
		Modulus of elasticity	183 GPa
		Ions release in 7 days	1,75 µg/cm ²
		Maximum cooking temperature	980°C
		Colour	White

MAGNUM NITENS TYPE 5

Composition		Physical and mechanical features	
Cobalt (Co)	62,5%	Solidus-liquidus temperature	1369 ÷ 1471 °C
Chrome (Cr)	28,5%	Thermal expansion coefficient	(25 ÷ 500 °C) 14,5 x 10 ⁻⁶ K ⁻¹
Molybdenum (Mo)	4%		(25 ÷ 600 °C) 14,7 x 10 ⁻⁶ K ⁻¹
Tungsten (W)	3%	Melting point	1530 °C
Others	Nb, Fe	Density	8,2 g/cmc
		Vickers hardness	302 HV10
		Percentage elongation at fracture	5 %
		Yield load strength (Rp0.2)	535 MPa
		Modulus of elasticity	195 GPa
		Ions release in 7 days	0.8 µg/cm ²
		Maximum cooking temperature	950°C
		Colour	White

MAGNUM SOLARE TYPE 4

Composizione		Proprietà fisiche e meccaniche	
Cobalt (Co)	66%	Solidus-liquidus temperature	1307 ÷ 1417 °C
Chrome (Cr)	27%	Thermal expansion coefficient	(25 ÷ 500 °C) 14,3 x 10 ⁻⁶ K ⁻¹
Molybdenum (Mo)	6%		(25 ÷ 600 °C) 14,5 x 10 ⁻⁶ K ⁻¹
Others	Si, Mn	Melting point	1470 °C
		Density	8,4 g/cmc
		Vickers hardness	255 HV10
		Percentage elongation at fracture	11 %
		Yield load strength (Rp0.2)	395 MPa
		Modulus of elasticity	233 GPa
		Maximum cooking temperature	980°C
		Colour	White

Chrome-Cobalt C€0425 ACCORDING TO: ISO 9693, ISO 22674

MAGNUM LUCENS TYPE 4

Composition		Physical and mechanical features	
Cobalt (Co)	63%	Solidus-liquidus temperature	1253 ÷ 1304 °C
Chrome (Cr)	28%	Thermal expansion coefficient	(25 ÷ 500 °C) 14,1 x 10 ⁻⁶ K ⁻¹
Niobio (Nb)	4%		(25 ÷ 600 °C) 14,5 x 10 ⁻⁶ K ⁻¹
Tungsten (W)	3%	Melting point	1360 °C
Others	Mn, Fe	Density	8,4 g/cm ³
		Vickers hardness	324 HV10
		Percentage elongation at fracture	3 %
		Yield load strength (Rp0.2)	475 MPa
		Modulus of elasticity	194 GPa
		Ions release in 7 days	0,8 µg/cm ²
		Maximum cooking temperature	950°C
		Colour	White

MAGNUM CERAMIC CO TYPE 5

Composition		Physical and mechanical features	
Cobalt (Co)	64%	Solidus-liquidus temperature	1309 ÷ 1417 °C
Chrome (Cr)	21%	Thermal expansion coefficient	(25 ÷ 500 °C) 14,1 x 10 ⁻⁶ K ⁻¹
Molybdenum (Mo)	6%		(25 ÷ 600 °C) 14,6 x 10 ⁻⁶ K ⁻¹
Tungsten (W)	6%	Melting point	1470 °C
Others	Si, Mn, Fe	Density	8,8 g/cm ³
		Vickers hardness	386 HV10
		Percentage elongation at fracture	10 %
		Yield load strength (Rp0.2)	570 MPa
		Modulus of elasticity	194 GPa
		Ions release in 7 days	0,6 µg/cm ²
		Maximum cooking temperature	935°C
		Colour	White



Nickel-Chrome **CE0425** ACCORDING TO: ISO 9693, ISO 22674

MAGNUM SATURNO TYPE 3

Composition		Physical and mechanical features	
Nickel (Ni)	63%	Solidus-liquidus temperature	1190 ÷ 1303 °C
Chrome (Cr)	26%	Thermal expansion coefficient	(25 ÷ 500 °C) 13,8 x 10 ⁻⁶ K ⁻¹
Molybdenum (Mo)	9%	Melting point	1360 °C
Silicon (Si)	1,5%	Density	8,2 g/cm ³
		Vickers hardness	173 HV10
		Percentage elongation at fracture	37 %
		Yield load strength (Rp0.2)	300 MPa
		Modulus of elasticity	197 GPa
		Ions release in 7 days	2,7 µg/cm ²
		Maximum cooking temperature	950°C
		Colour	White

MAGNUM CLARUM TYPE 3

Composition		Physical and mechanical features	
Nickel (Ni)	63%	Solidus-liquidus temperature	1298 ÷ 1344 °C
Chrome (Cr)	25%	Thermal expansion coefficient	(25 ÷ 500 °C) 13,7 x 10 ⁻⁶ K ⁻¹
Molybdenum (Mo)	9%		(25 ÷ 600 °C) 14 x 10 ⁻⁶ K ⁻¹
Silicon (Si)	2%	Melting point	1400 °C
		Density	8,3 g/cm ³
		Vickers hardness	180 HV10
		Percentage elongation at fracture	26 %
		Yield load strength (Rp0.2)	360 MPa
		Modulus of elasticity	191 GPa
		Ions release in 7 days	1,8 µg/cm ²
		Maximum cooking temperature	950°C
		Colour	White

Nickel-Chrome **CE 0425** ACCORDING TO: ISO 9693, ISO 22674

MAGNUM CERAMIC S TYPE 4

Composition		Physical and mechanical features	
Nickel (Ni)	65%	Solidus-liquidus temperature	1312 ÷ 1369 °C
Chrome (Cr)	24%	Thermal expansion coefficient	(25 ÷ 500 °C) $13,7 \times 10^{-6} \text{ K}^{-1}$
Molybdenum (Mo)	10%		(25 ÷ 600 °C) $14,1 \times 10^{-6} \text{ K}^{-1}$
Others	Si, Fe	Melting point	1420°C
		Density	8,4 g/cm ³
		Vickers hardness	188 HV10
		Percentage elongation at fracture	9 %
		Yield load strength (Rp0.2)	360 MPa
		Modulus of elasticity	190 GPa
		Ions release in 7 days	1,6 µg/cm ²
		Maximum cooking temperature	900°C
		Colour	White





DENTAL ALLOYS FOR PLATE PROSTHESES

The plate prosthesis is a mobile partial dental prosthesis which, by exploiting the elasticity of the alloy, allows it to be linked to the natural teeth through fused hooks. In case of contiguous teeth on both sides we talk about “interdental prostheses”; while, in the absence of the terminal tooth to fix the prosthesis, we talk about “cantilever prosthesis”.

Casting alloys produced by Mesa are characterized by:

- **High tensile strength and excellent workability**, which allow to obtain smooth and compact surfaces with reduced oxide formation.
- **Low specific weight and excellent mechanical properties**, which allow the most demanding technicians to create unique products, with a reduced thickness.

Chrome-Cobalt $\text{C}\epsilon\text{0425}$ ACCORDING TO: ISO 22674

MAGNUM VIP-A TYPE 5

Composition		Physical and mechanical features	
Cobalt (Co)	64%	Solidus-liquidus temperature	1350 ÷ 1406 °C
Chrome (Cr)	29%	Melting point	1460 °C
Molybdenum (Mo)	6%	Density	8,4 g/cm ³
Others	C, Si, Mn, Fe	Vickers hardness	386 HV10
		Percentage elongation at fracture	6 %
		Yield load strength (Rp0.2)	580 MPa
		Modulus of elasticity	211 GPa
		Ions release in 7 days	1,1 µg/cm ²
		Colour	White

MAGNUM HBA TYPE 5

Composition		Physical and mechanical features	
Cobalt (Co)	62%	Solidus-liquidus temperature	1340 ÷ 1400 °C
Chrome (Cr)	31%	Melting point	1450 °C
Molybdenum (Mo)	5%	Density	8,3 g/cm ³
Others	C, Si, Mn, Fe	Vickers hardness	389 HV10
		Percentage elongation at fracture	6 %
		Yield load strength (Rp0.2)	610 MPa
		Modulus of elasticity	200 GPa
		Ions release in 7 days	0,49 µg/cm ²
		Maximum cooking temperature	980°C
		Colour	White

Chrome-Cobalt **CC0425** ACCORDING TO: ISO 22674

MAGNUM H60 TYPE 5

Composition		Physical and mechanical features	
Cobalt (Co)	63%	Solidus-liquidus temperature	1321 ÷ 1407 °C
Chrome (Cr)	29%	Melting point	1460 °C
Molybdenum (Mo)	6,5%	Density	8,3 g/cm ³
Others	C, Si, Mn, Fe	Vickers hardness	394 HV10
		Percentage elongation at fracture	6 %
		Yield load strength (Rp0.2)	545 MPa
		Modulus of elasticity	209 GPa
		Ions release in 7 days	0.6 µg/cm ²
		Colour	White

MAGNUM H50 TYPE 5

Composition		Physical and mechanical features	
Cobalt (Co)	64%	Solidus-liquidus temperature	1334 ÷ 1405 °C
Chrome (Cr)	29%	Melting point	1460 °C
Molybdenum (Mo)	6,5%	Density	8,3 g/cm ³
Others	C, Si, Mn, Fe	Vickers hardness	374 HV10
		Percentage elongation at fracture	6 %
		Yield load strength (Rp0.2)	525 MPa
		Modulus of elasticity	207 GPa
		Ions release in 7 days	0.6 µg/cm ²
		Colour	White



A bridge, by definition, is a fixed prosthesis which enables to replace the missing teeth.

A bridge involves at least two teeth, also called “pillar teeth”, usually located at both sides of the place created by the missing tooth. The bridge is anchored on those teeth (usually they are crowns), in this way the missing teeth are fixed (intermediate elements).

A bridge is usually formed by offers and by one or more intermediate elements. For bridges and crowns Mesa offer the alloy Magnum Ni-Cr-Fe, Nickel-Iron based, which is characterized by low hardness and reduced cost. Magnum Ni-Cr-Fe is distinguished by high resistance to corrosion and good biocompatibility, as assured by tests carried out in compliance with standards ISO 10993-5 and ISO 22674.

Chrome-Nickel-Iron **CE 0425** ACCORDING TO: ISO 22674

MAGNUM
Ni-Cr-Fe TYPE 2

Composition		Physical and mechanical features	
Iron (Fe)	42%	Solidus-liquidus temperature	1333 ÷ 1380 °C
Nickel (Ni)	27%	Melting point	1430 °C
Chrome (Cr)	22%	Density	7,8 g/cmc
Silicon (Si)	4%	Vickers hardness	168 HV10
Others	C, Si, Mn, Fe	Percentage elongation at fracture	25 %
		Yield load strength (Rp0.2)	250 MPa
		Modulus of elasticity	205 GPa
		Ions release in 7 days	137 µg/cm ²
		Colour	White





DENTAL ALLOYS FOR WELDING

Dental alloys for welding manufactured by Mesa are highly biocompatible and manufactured in accordance with ISO 9333:2006.

Mesa offers a **wide range of alloys for welding**, having different chemical compositions and consequently a good adaptability to all alloys.

Our alloys for welding is available in the following sizes:

ROUGH STICK DIAMETER: 1.7 mm LENGTH: 75 mm

Chrome-Cobalt Chrome-Cobalt-Nickel **CE0425** ACCORDING TO: ISO 9333

MAGNUM WELDING CO

Composition		Physical and mechanical features	
Cobalt (Co)	62%	Solidus-liquidus temperature	1071 ÷ 1260 °C
Chrome (Cr)	29%	Thermal expansion coefficient	(25 ÷ 500 °C) 15,5 x 10 ⁻⁶ K ⁻¹
Molybdenum (Mo)	4%		(25 ÷ 600 °C) 15,8 x 10 ⁻⁶ K ⁻¹
Silicon (Si)	3%	Melting point	1310 °C
Others	C, Mn, Fe	Density	8,2 g/cmc
		Colour	White

MAGNUM WELDING A

Composition		Physical and mechanical features	
Cobalt (Co)	52%	Solidus-liquidus temperature	992 ÷ 1185 °C
Chrome (Cr)	20%	Melting point	1240 °C
Nickel (Ni)	21%	Density	8,1 g/cmc
Others	Fe, Si, C, Mn	Colour	White

MAGNUM WELDING B

Composition		Physical and mechanical features	
Cobalt (Co)	31%	Solidus-liquidus temperature	1033 ÷ 1210 °C
Cromo (Cr)	21%	Melting point	1260 °C
Nickel (Ni)	39%	Density	8,2 g/cmc
Molybdenum (Mo)	4%	Colour	White
Others	C, Mn		





DISCS AND BARS FOR CAD/CAM PROCESSING

CAD (Computer Aided Design) software is a system that allows you to carry out the digital design of dental devices and then produce prosthetic rehabilitations using CAM (Computer Aided Manufacturing).

CHROME-COBALT DISCS FOR CAD-CAM PROCESSING

Mesa has been producing Cr-Co discs for CAD-CAM machining systems for more than 15 years now.

The Cr-Co CAD-CAM discs are supplied as **Magnum Splendidum** and **Magnum Solare**.

Our discs are characterized by:

- **Facilitated milling** determined by a perfect balance between Vickers hardness and modulus of elasticity, avoiding damage to the ceramics and at the same time allowing excellent workability.
- **Excellent polishability** with less wear on the cutters and less effort on the mandrel.

Following the available heights and diameters:

DIAMETER	HEIGHT
98,5 mm	8 mm
	10 mm
	12 mm
	13,5 mm
	14 mm
	15 mm
	16 mm
	18 mm
	20 mm
	22 mm
	24,5 mm
	25 mm



CHROME-COBALT BARS FOR CAD-CAM PROCESSING

Mesa has recently introduced bars for CAD-CAM machining into its range of products. They have been designed, in particular, to reduce processing costs and to ensure lower material consumption.

The bars are supplied as **Magnum Splendidum** and **Magnum Solare**

Following the available
lengths and diameters:

LENGTH		DIAMETER	
1000	mm	5	mm
3000	mm	6	mm
		6,35	mm
		8	mm
		10	mm
		12	mm
		14	mm
		16	mm
		18	mm
		20	mm

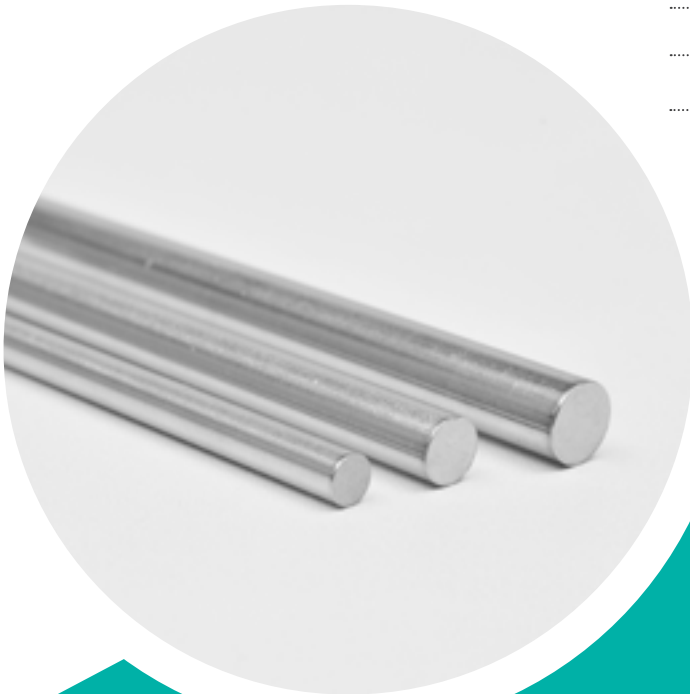

Chrome-Cobalt **CE 0425** ACCORDING TO: ISO 9693, ISO 22674

MAGNUM SPLENDIDUM TYPE 3

Composition		Physical and mechanical features	
Cobalt (Co)	60%	Solidus-liquidus temperature	1308 ÷ 1384 °C
Chrome (Cr)	28%	Thermal expansion coefficient	(25 ÷ 500 °C) 14,2 x 10 ⁻⁶ K ⁻¹
Silicon (Si)	1,5%		(25 ÷ 600 °C) 14,4 x 10 ⁻⁶ K ⁻¹
Tungsten (W)	9%	Melting point	1440 °C
Others	Mn, Fe	Density	8,5 g/cmc
		Vickers hardness	273 HV10
		Percentage elongation at fracture	16 %
		Yield load strength (Rp0.2)	360 MPa
		Modulus of elasticity	183 GPa
		Ions release in 7 days	1,75 µg/cm ²
		Maximum cooking temperature	980°C
		Colour	White

MAGNUM SOLARE TYPE 4

Composition		Physical and mechanical features	
Cobalt (Co)	66%	Solidus-liquidus temperature	1307 ÷ 1417 °C
Chrome (Cr)	27%	Thermal expansion coefficient	(25 ÷ 500 °C) 14,3 x 10 ⁻⁶ K ⁻¹
Molybdenum (Mo)	6%		(25 ÷ 600 °C) 14,5 x 10 ⁻⁶ K ⁻¹
Others	Si, Mn	Melting point	1470 °C
		Density	8,4 g/cmc
		Vickers hardness	255 HV10
		Percentage elongation at fracture	11 %
		Yield load strength (Rp0.2)	395 MPa
		Modulus of elasticity	233 GPa
		Maximum cooking temperature	980°C
		Colour	White



TITANIUM DISCS FOR CAD-CAM PROCESSING

Mesa is pleased to introduce in its range of products an innovative material, Titanium Grade 23 (commonly known as Grade 5 ELI, Extra Low Interstitial).

This alloy, compared to the Titanium Grade 5, has a lower percentage of interstitial elements, such as oxygen and iron: this characteristic provides better ductility and tensile strength.

This material is:

- **highly biocompatible**
- **corrosion resistant**
- **light**
- **easy to mill**
- **very tough**

The alloy is called Magnum Hyperone, inspired by the Greek mythological character Hyperion, the Titan of observance.

Following the available heights and diameters for discs:

DIAMETER		HEIGHT	
98,5	mm	8	mm
		10	mm
		12	mm
		13,5	mm
		14	mm
		15	mm
		16	mm
		18	mm
		20	mm
		22	mm
		24,5	mm
		25	mm

Titanium Ti 0425 ACCORDING TO: ASTM F136

Composition		Physical and mechanical features	
Titanium (Ti)	90 %	Solidus-liquidus temperature	1605 ÷ 1660 °C
Aluminium (Al)	6 %	Melting point	1710 °C
Vanadium (V)	4 %	Density	4,426 g/cm ³
Others	Fe	Vickers hardness	312 HV10
		Percentage elongation at fracture	14 %
		Yield load strength (Rp0.2)	880 MPa
		Modulus of elasticity	114 GPa
		Colour	White





ERGAL DISCS FOR CAD-CAM PROCESSING

Mesa is pleased to introduce the new ERGAL discs.

Thanks to its excellent milling performance, this alloy is excellent for the production of trial artifacts.

Furthermore, it guarantees extremely high precision and, at the same time, extreme ease of production.

For this reason, Ergal allows you to create products easily, quickly and economically.

Following the available sizes:

DIAMETER		HEIGHT	
98,5	mm	16	mm
		20	mm



CHROME-COBALT AND TITANIUM QBAR

Mesa is pleased to introduce in its range of products **Magnum Splendidum** and **Magnum Hyperone** Qbar.

These are Chrome-Cobalt and Titanium bars with unique characteristics, intended for the production of immediate loading prostheses.

Thanks to their extreme versatility, they provide excellent adaptation and personalization features.

From a single device it is possible to create several products.

Furthermore, thanks to its preforming, it is possible to use the device for many different solutions.

Qbars are available in the following size: 3x2x80 mm

Chrome-Cobalt **CE0425** ACCORDING TO: ISO 9693, ISO 22674

MAGNUM SPLENDIDUM TIPO 3

Composizione		Proprietà fisiche e meccaniche	
Cobalt (Co)	60%	Solidus-liquidus temperature	1308 ÷ 1384 °C
Chrome (Cr)	28%	Thermal expansion coefficient	(25 ÷ 500 °C) 14,2 x 10 ⁻⁶ K ⁻¹
Silicon (Si)	1,5%		(25 ÷ 600 °C) 14,4 x 10 ⁻⁶ K ⁻¹
Tungsten (W)	9%	Melting point	1440 °C
Others	Mn, Fe	Density	8,5 g/cmc
		Vickers hardness	273 HV10
		Percentage elongation at fracture	16 %
		Yield load strength (Rp0.2)	360 MPa
		Modulus of elasticity	183 GPa
		Ions release in 7 days	1,75 µg/cm ²
		Maximum cooking temperature	980°C
		Colour	White

Titanium **CE0425** ACCORDING TO: ASTM F136

MAGNUM HYPERONE TIPO 4

Composizione		Proprietà fisiche e meccaniche	
Titanium (Ti)	90%	Solidus-liquidus temperature	1605 ÷ 1660 °C
Aluminium (Al)	6%	Melting point	1710 °C
Vanadium (V)	4%	Density	4,426 g/cmc
Others	Fe	Vickers hardness	312 HV10
		Percentage elongation at fracture	14 %
		Yield load strength (Rp0.2)	880 MPa
		Modulus of elasticity	114 GPa
		Colour	White



OVERCASTABLE ABUTMENTS

MESA Research and Development department, constantly cooperating with a group of dental technicians, designed a line of compatible Chrome-Cobalt abutments that feature a unique overcasting method.

Mesa overcastable abutments, which offer superior accuracy of engagement with the dental implant, provide peculiar **advantages thanks to the absence of the traditional calcinable plastic modelling cannula.**

Mesa overcastable abutments are produced with our Chrome-Cobalt alloy, **Magnum Splendidum**, that has excellent characteristics and is ideal for overcasting.

MESA OVERCASTABLE' FEATURES

MESA overcastable abutments:

- Replace the classic connection system made of calcinable plastic;
- Are compatible with the main implant systems;
- Are available as rotating and non-rotating;
- Can be used for single crowns or multiple screw-retained structures.

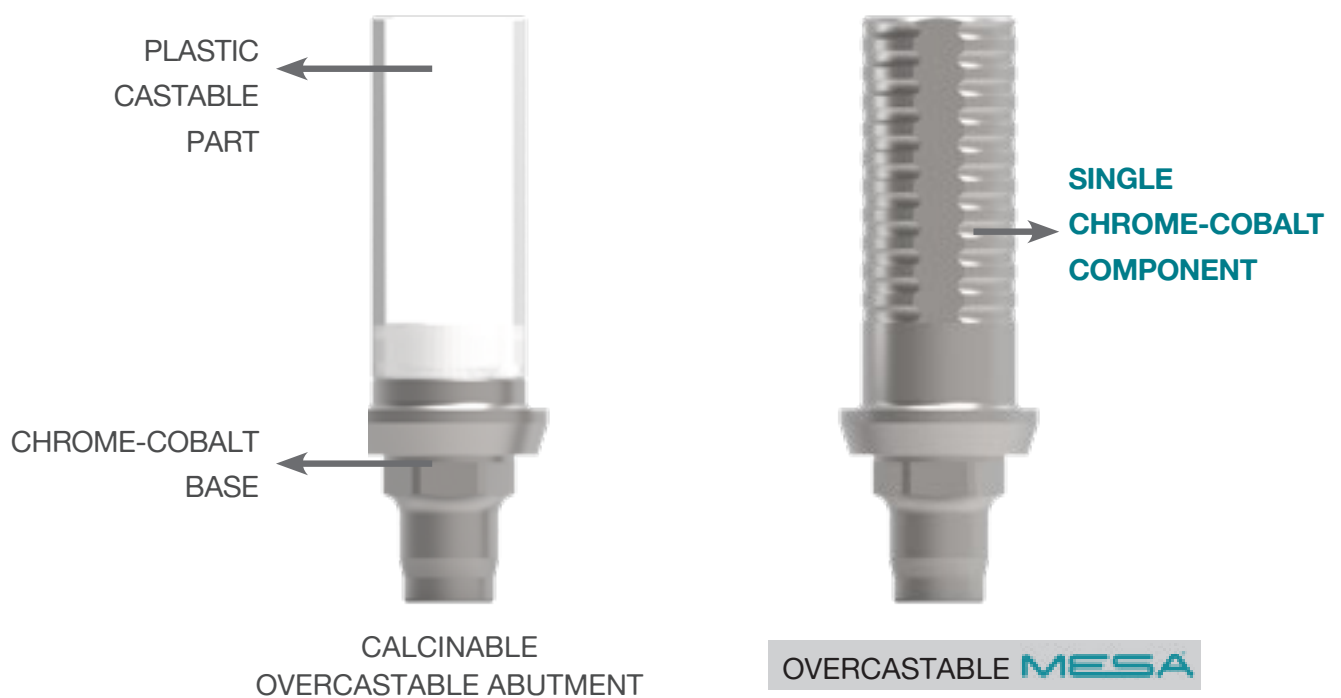

THEY CAN BE USED FOR DIFFERENT NEEDS:

- Overcasting: with lost wax modelling or by digital modelling
- Welding
- Bonding milled or melted structures
- Can also be used as abutments
- Chrome-Cobalt MUA sleeves also available

WHY CHOOSE MESA OVERCASTABLE ABUTMENTS?

Mesa overcastable abutments features are:

- **NON-DEFORMABLE SCREW HOLE:**

the inside of Mesa overcastable abutments is unchanged by the melting and the screws fit perfectly inside the hole.

- **MELTING WITHOUT IMPURITIES IN THE SCREW CHANNEL:**

no combustion residues from the melting of the calcinable plastic, thus resulting in an improved melting surface.

- **OPTIMUM WELDING BETWEEN THE TWO METALS:**

the perfect coupling between the two alloys Magnum Splendidum and Magnum Lucens during melting results in optimal adhesion and guarantees maximum precision in the welding and prevents the detachment of the two metals.

The oxidation for both alloys is non-aggressive, mild and clear.





TIPS FOR CASTING MESA OVERCASTABLE ABUTMENTS

- **Some technical tips suggested by our team of dental technicians:**
- **Coatings:** it is recommended to use only coatings with phosphate bond
- **Preheating:** to ensure that the casting is complete, keep the cylinder at 850 °C for at least 50% longer than the standard time
- **Melting or casting:** do not exceed 1410 °C during melting
- **Cooling:** allow the cylinder to cool to room temperature
- **Opening the cylinder:** do not use hydrofluoric acid to remove the coating
- **Sandblasting:** sandblast with fine sand (from 90µm to 150µm) at a pressure of 1.5-2.0 bar. Do not sandblast the implant connection
- **Finishing:** Do not use hydrofluoric acid to remove oxides
- **Aesthetic coatings:** to ensure compatibility with the Cr-Co abutment, coefficient of thermal expansion (CTE) of the ceramic must be at least 90% of that of the alloy.

COMPATIBLE OVERCASTABLE CR-CO COMPONENTS

Overcastable components and related screws compatible
with the following brands are available:

- **BIOMET 3i[®]**
 - Esagono Esterno
 - Certain[®]
 - MULTI UNIT

- **DENTAURUM[®]**
 - TioLogic[®] e TioLogic[®] ST

- **JDENTAL CARE[®]**
 - Evolution[®]
 - Evolution[®] Plus
 - Evolution[®]S
 - JD ICON[®] ULTRA.S
 - MULTI UNIT

- **MEGAGEN[®]**
 - AnyOne[®]

- **SWEDEN & MARTINA[®]**
 - Premium Kohno One[®]
 - Outlink2[®]
 - MULTI UNIT

- **ZIMMER[®]**
 - Screw Vent

The trademarks mentioned are not owned by Mesa Italia Srl.
All logos and trademarks belong to their respective owners and are mentioned only to simplify product search.
Compatible products are exclusively non-original spare parts.

INTERNATIONAL EVENTS



إيكدك
AEDDC
DUBAI



colloquium dental



IDS[®]
COLOGNE



EXPO
DENTAL
MEETING



LAST
labday[®]
CHICAGO

MESA ITALIA S.R.L.

Via dell'Artigianato, 37
25039 Travagliato (bs) - Italy
tel. +39 030 6863251
info@mesaitalia.it
www.mesaitalia.it

